

1/35 Sherman T54E1 Workable Track Set



Before You Begin

A few things to go over

- **Glue is required!** A sturdy PVA white glue is recommended, but super glue can also be used if preferred.
- **So is cleanup!** Expect some light sanding around support contact points.
- **Tools can help.** The included track jig and connector holders speed up the build process.
- **Tracks can be fussy.** Worakble, link-and-length, rubber bands. Doesn't matter. Tracks can be fussy. Doogs Studios tracks are designed to minimize that fussiness, but with something like 1/35 Sherman tracks, there's no fully escaping it.

1. Get familiar with the track contents

This track set consists of three major components: track links, male end connectors with full-length track pins, and female end connectors that glue onto the ends of those pins.

This integrated design also makes assembly smoother, faster, and even fun (well...as fun as track assembly can ever be...)

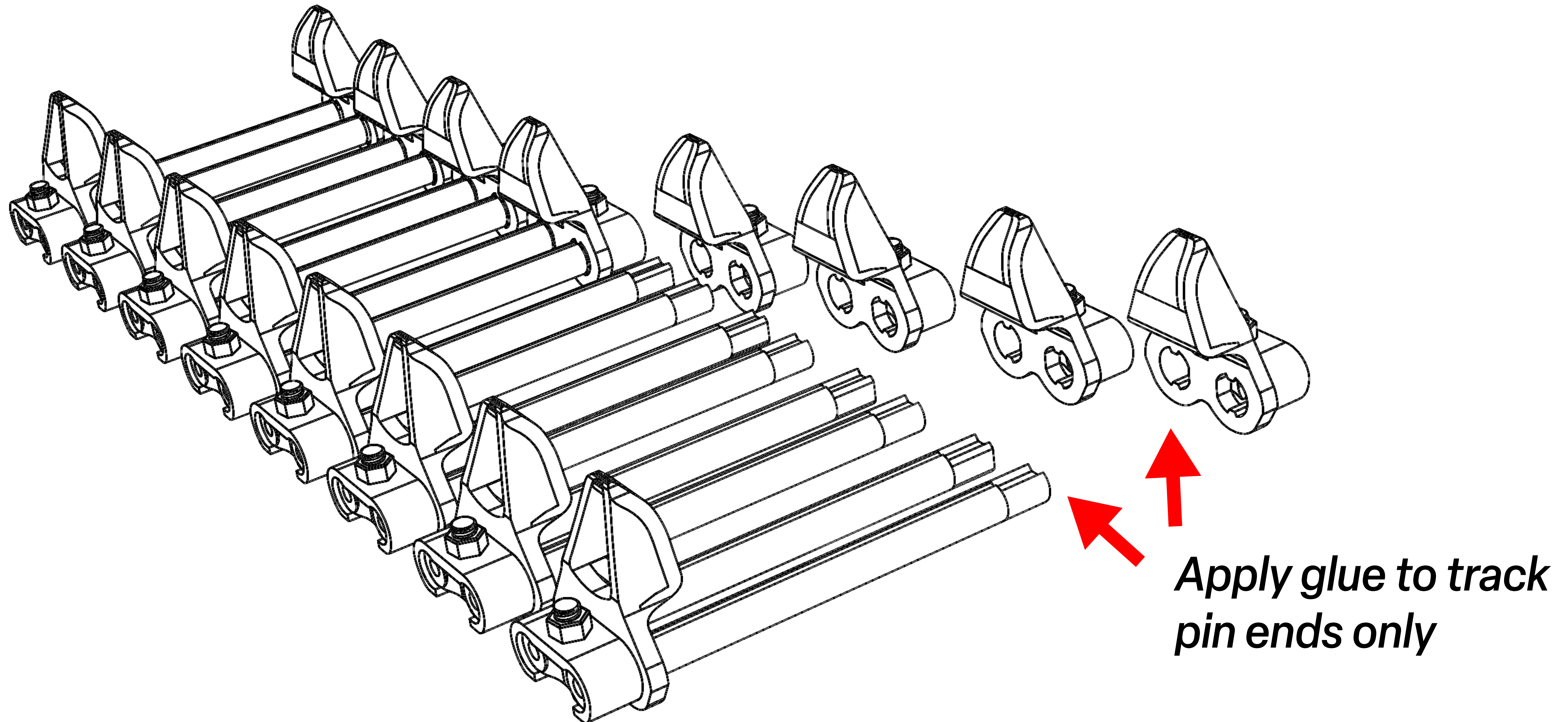

2. Get jiggy with it

Place track links
onto the jig outer
face down

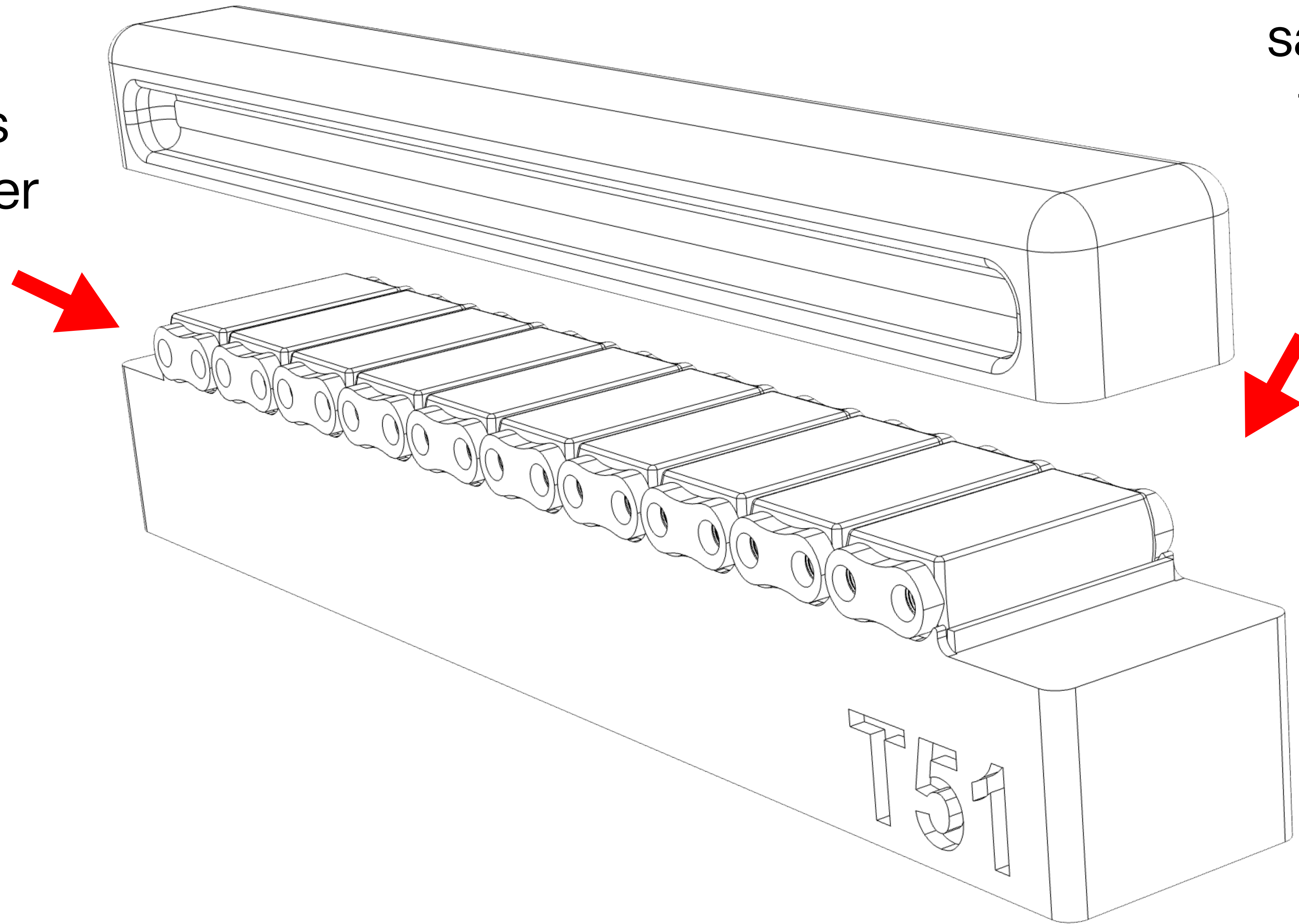

Use the jig top to
sandwich the
track links in
place.

3. Insert pins into track links

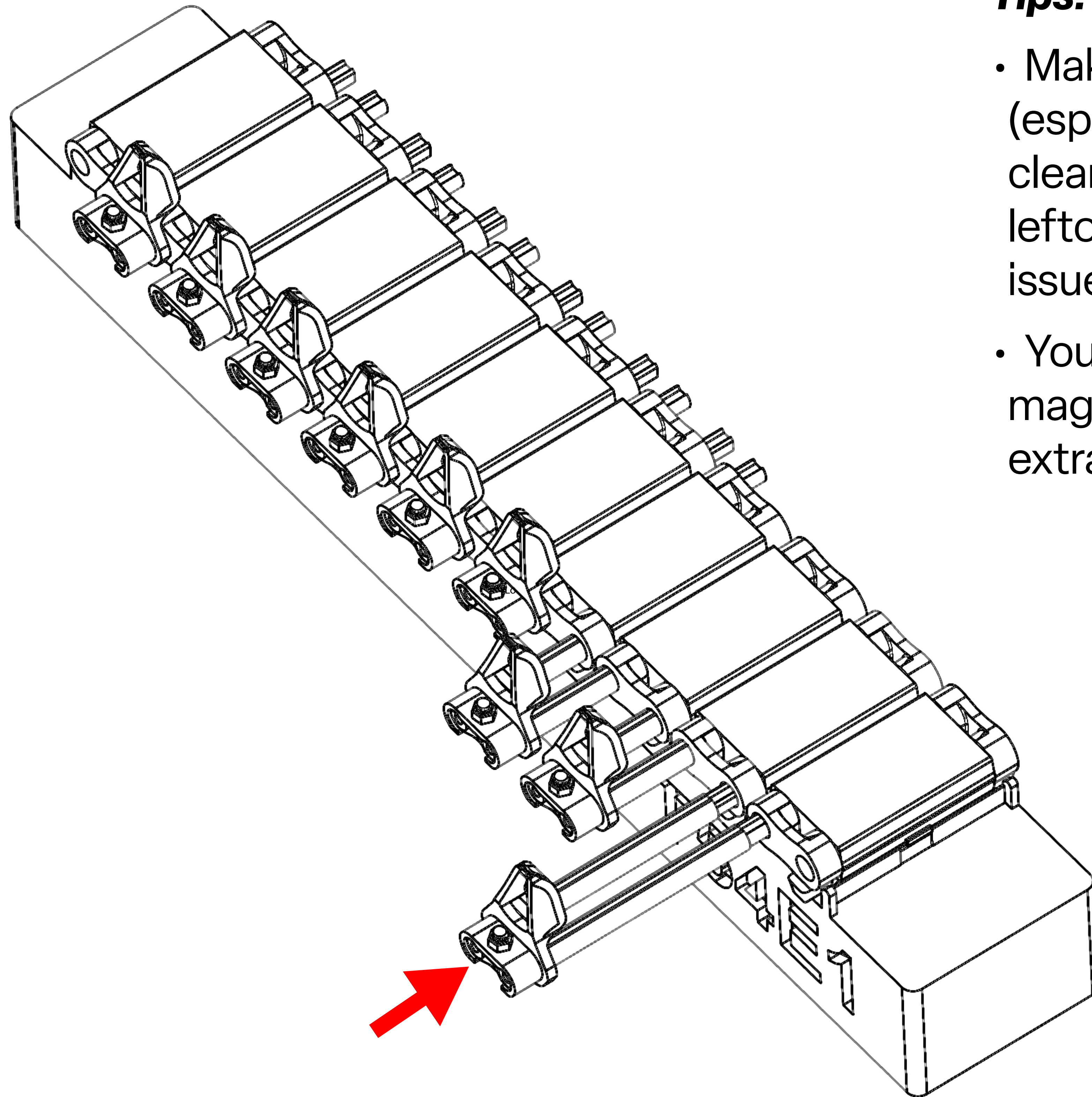

Tips!

- Make sure your connectors (especially the pin ends) are cleaned up. A small bit of leftover support can cause issues.
- You can install 6x2mm magnets in the jig base for extra stability.

4. Attach end connectors

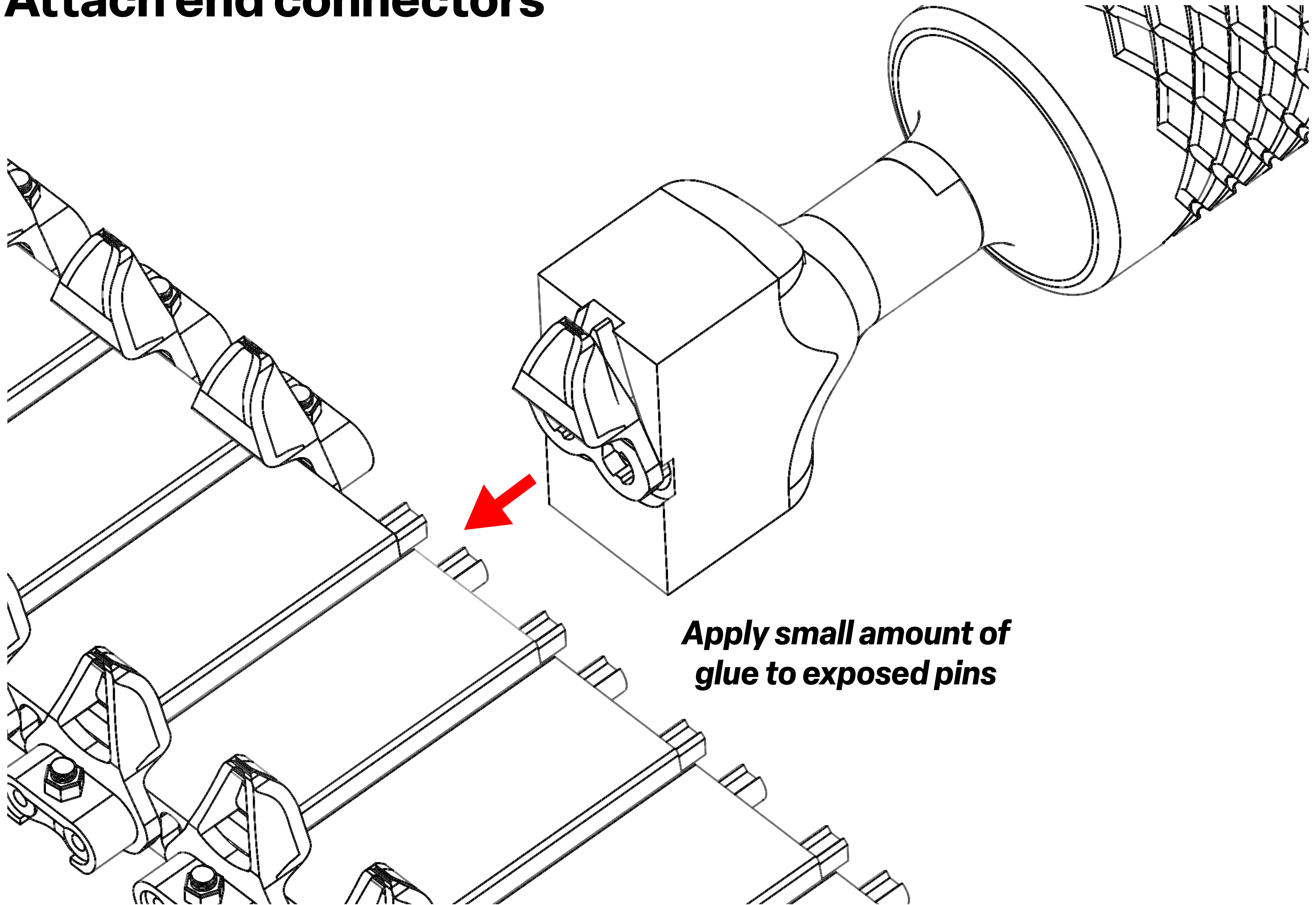

5. Rinse and repeat

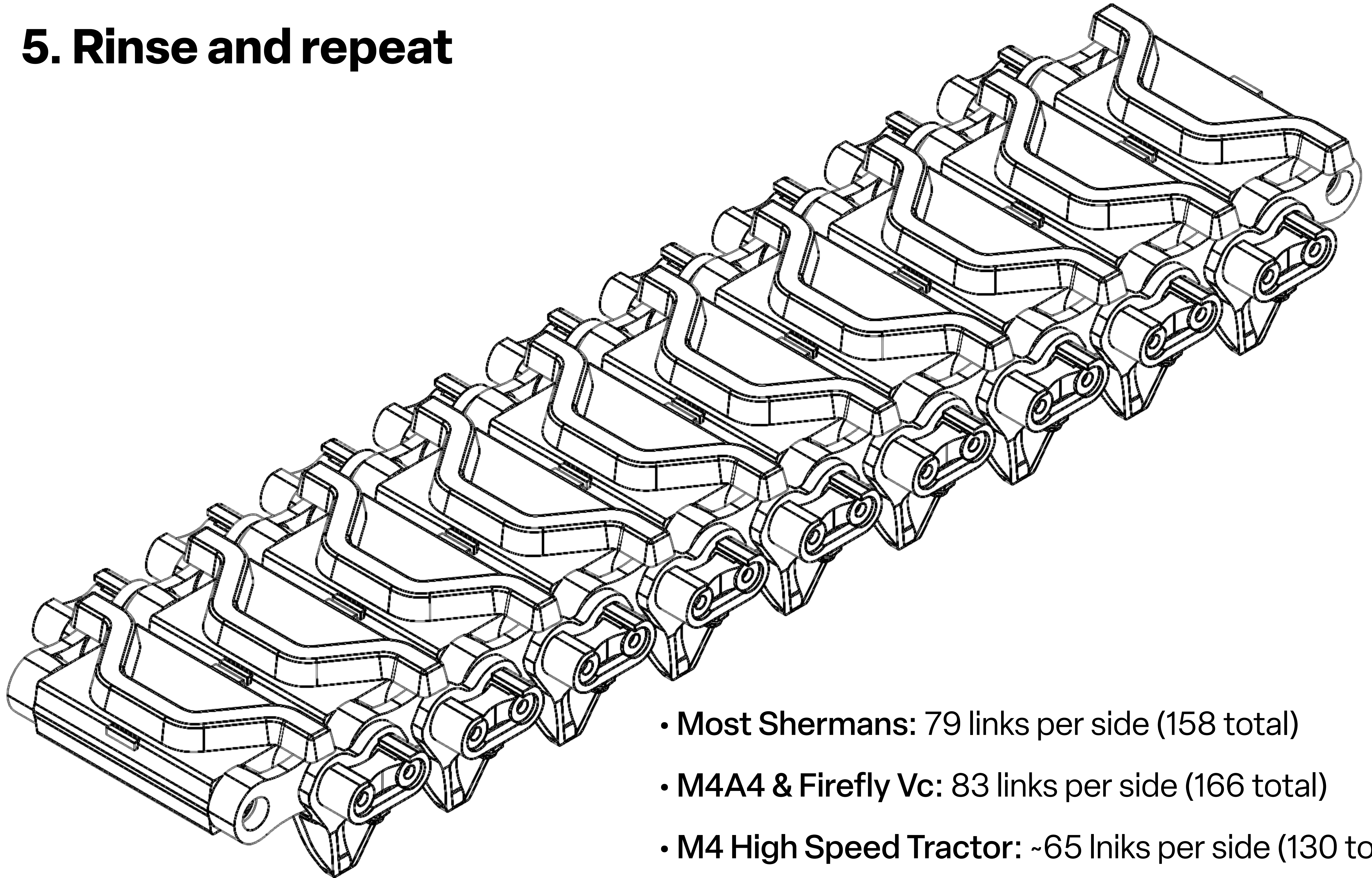

- Most Shermans: 79 links per side (158 total)
- M4A4 & Firefly Vc: 83 links per side (166 total)
- M4 High Speed Tractor: ~65 links per side (130 total)
- M10, M36, M7 and other: ~79 links per side (158 total)

SHOW US YOUR TRACKS!

Share in-progress and final pics of our tracks on your build and get 20% off your next order!

Just tag *@doogsstudios* on social media or email *doogs@doogsstudios.com*